

FEATURES

- **Switchable inputs:**
Current 0(4)...20 mA or
Voltage 0(2)...10 V
- **Outputs simultaneous:**
Current 0(4)...20 mA active or
loop-powered
Voltage 0(2)...10 V
- **Function, switchable:**
- fixed calibration or
- adjustable by trimmer or
- simulation mode for outputs
- **Galvanic 3-way isolation**
of 2,5 kV
- **Low internal consumption**

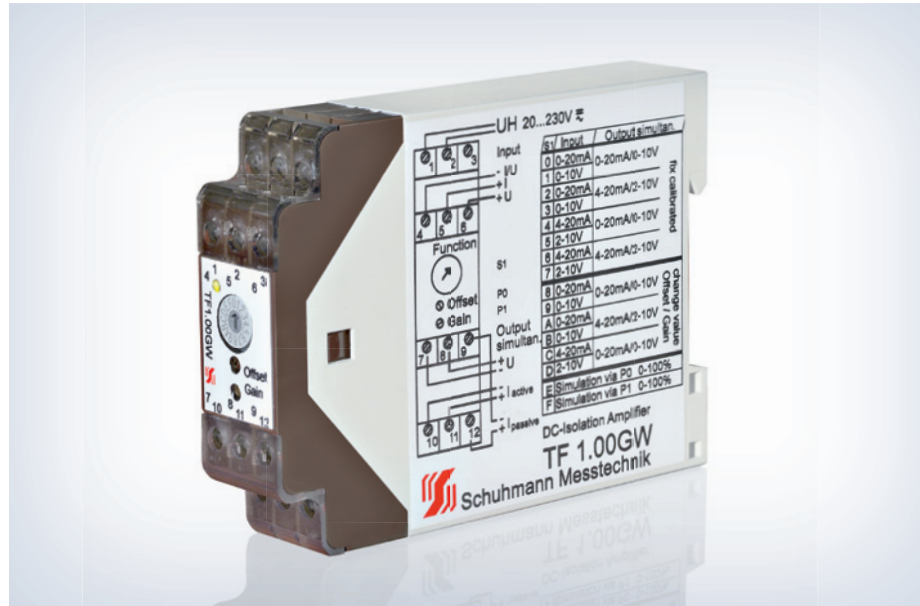

FUNCTION

Amplifiers are used for the galvanic isolation or conversion of analog signals. This guarantees a safe decoupling between sensor and evaluation circuit and any influence of other sensor circuit among each other is absolutely impossible. This Amplifier is equipped with standard current and voltage inputs as well as current and voltage outputs.

The TF 1.00 GW can be switched to different characteristics of transmission by turn-switch. Fixed calibrated measuring ranges for input and output are stored in switch setting 0...7. In position 8...D the transmission ranges can be adjusted by zero point and range trimmer. Position E and F are used for simulation during initial operation, here a fixed output value can be generated by zero point and range trimmer, without input signal.

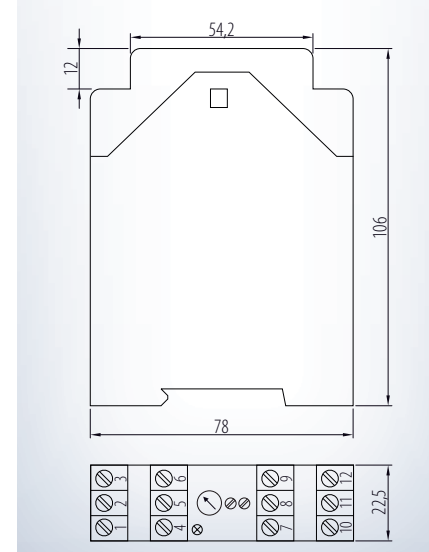
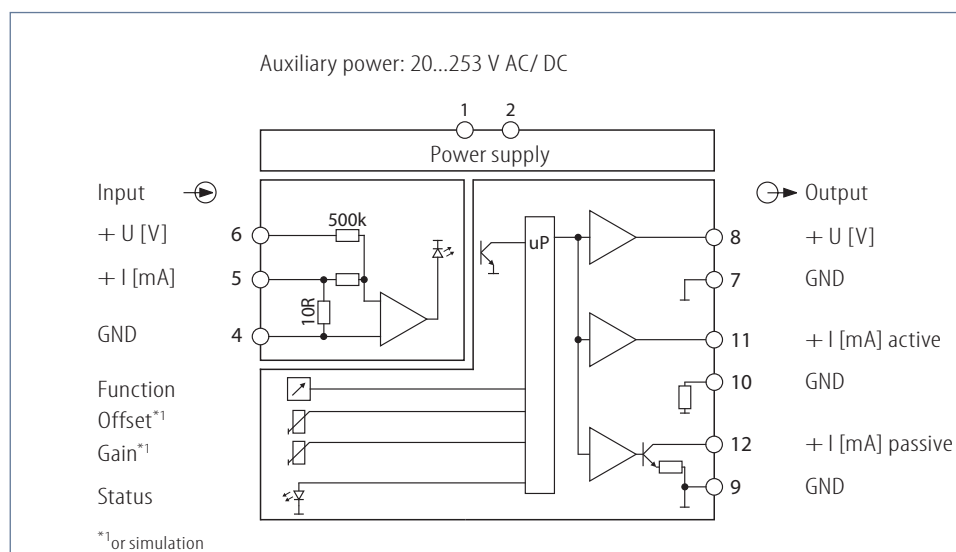

TF 1.00 GW

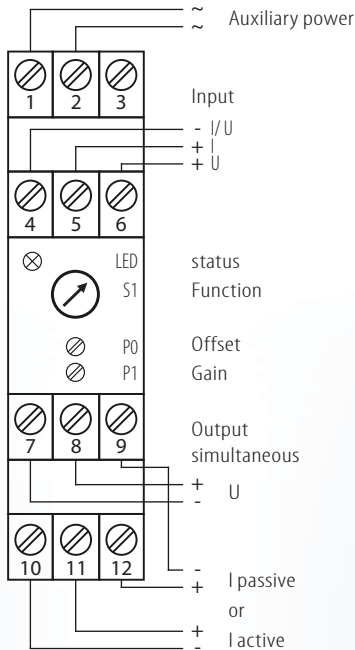

Input:

I: DC current:	0(4)...20 mA	input resistance approx. 10 Ω
connection:	terminal 4 -, 5 +	
U: DC voltage:	0(2)...10 V	input resistance approx. 500 kΩ
connection:	terminal 4 -, 6 +	

Output:

I: load-independent DC current:	0(4)...20 mA	permissible load max. 500 Ω
connection:	terminal 10 -, 11 +	
or:		
loop-powered DC current:	0(4)...20 mA	max. permissible voltage 30 V
connection:	terminal 9 -, 12 +	
U: load-independent DC voltage:	0(2)...10 V	permissible load ≥ 2 kΩ
connection:	terminal 7 -, 8 +	

The maximum limits for current- and voltage output are fixed at 22 mA respectively 11 V.

Adjustment:

The characteristics of transmission are adjustable by turn-switch.

S1	Input	Output simultan.	Position turn-switch S1	
0	0-20 mA	0-20 mA / 0-10 V	0...7	Inputs and outputs are fixed calibrated, the trimmer for zero point and range are here without function.
1	0-10 V	4-20 mA / 2-10 V	fixed calibrated	
2	0-20 mA			
3	0-10 V			
4	4-20 mA	0-20 mA / 0-10 V		
5	2-10 V	4-20 mA / 2-10 V		
6	4-20 mA	4-20 mA / 2-10 V		
7	2-10 V	0-20 mA / 0-10 V		8...D
8	0-20 mA			
9	0-10 V			
A	0-20 mA			
B	0-10 V	4-20 mA / 2-10 V	change value Offset/Gain	
C	4-20 mA	0-20 mA / 0-10 V		
D	2-10 V			
E	Simulation via P0 0-100%			E
F	Simulation via P1 0-100%		F	Simulation with trimmer P1: 0...100% output

Display:

LED status:	green, active	input signals are in standard range, device ready for use
	green, flashing	input signal out of the acceptable range or exceeding of measuring range or simulation mode

Environmental conditions:

Storage temperature:	-40...+70 °C
Operating temperature:	0...55 °C
Isolation voltage:	2,5 kV eff. 1 sec. input-output 2,5 kV eff. 1 sec. auxiliary voltage

Auxiliary power:

Wide range:	20...253 V AC/ DC approx. 6...40 mA
Influence of auxiliary power:	< 0,1 %

Characteristics of transmission:

Transmission error:	< 0,12 %
Resolution:	15 bit
Linearity error:	< 0,1 %
Temperature error:	< 100 ppm/ K
Load influence I:	< 50 ppm of final value
Load influence U:	< 0,2 % at 2 kΩ load
Setting time:	< 100 msec.

Directive:

EMC Directive:	2004/108/EC*
Low Voltage Directive:	2006/95/EC
*minimum deviations possible during HF-radiation influence	

Mounting details:

Housing for top hat rail	
Type of protection:	IP 40 housing IP 10 clamps
Mounting rail fixed according to	EN 50022-35 x 6,2 mm
Width:	22,5 mm
Weight:	150 g
Material:	Noryl V0 150/ ABS
Flammability class:	ISO R75A 147°C/ 90°C
Approval:	CE
Connection:	screw clamps ≤ 2 x 2,5 mm ²

Please check switch position before initial operation!

Ordering information:

Type: TF 1.00 GW wide range

Schuhmann GmbH & Co. KG
Kleingartacher Str. 21
D-74363 Güglingen
Tel. + 49 71 35 50 56
Fax + 49 71 35 53 55
www.schuhmann-messtechnik.de