

Feeding Isolating STV 2.00 Amplifier

Features:

calibrated change-over of signals

power supply of 2-wire transducers with flexible selection of signals as well as connection to active 2-wire and passive 3-wire transmitters

narrow housing 22,5 mm

pluggable clamps

3-way isolation

short-circuit proof

input and output circuit

flexible and high-precision change-over

calibrated ranges 60mV, 1V, 10V, ±10V, 1mA, 0..20mA, 4..20mA, 20..0mA, 20...4mA, ±20mA

output ranges 0...10V, 2..10V, ±10V, 0..20mA, 4..20mA, ±20mA

linearity tolerance <0,1 % of measuring value

frequency range 0...1kHz

bipolar inputs and outputs

wide range power 20...253V AC/DC



Application:

The Universal Feeding Isolating Amplifier is especially suited for the flexible and precise application by its **multi-functionality**, its space and cost saving narrow housing of 22,5 mm and its pluggable connection technique. High isolation and a galvanically safe 3-way isolation protect against faulty measurement or damage of the following instruments, such as e.g. analog control devices, measuring control rooms, guidance systems, PLC units. The input and output sides are protected against overvoltage.

Special features of the Universal Feeding Isolating Amplifier are a high transmission accuracy and long-term stability by the combination of modern analog and digital technology. The application range includes: supply of transducers, e.g. for measuring of water hardness, pressure sensors, level sensors, measuring heads for temperature measurement, 2- and 3-wire transmitters, recording of rotation direction and speed by bipolar inputs and outputs, etc.

Function:

Precise calibration and high-precision potential isolation: Universal Feeding Amplifier with calibrated switchable measuring ranges for the different analog measuring signals for conversion and galvanic isolation.

The device is designed for universal application and processes different input and output currents. The change-over is performed by laterally installed turn-switch without opening housing. Optionally freely adjustable characteristics and

conversion are possible by software parameterization. Changes and adjustments on site are carried out quickly and without any problems. Easy transmission of parameters to other transducers.

The adjustment is controlled and regulated by a microcontroller, malfunctions will be indicated by a flashing LED on front side. Due to the wide range power the local different supply voltages are no problem for the user.

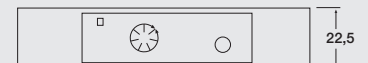
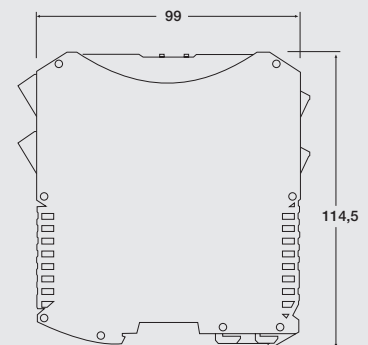

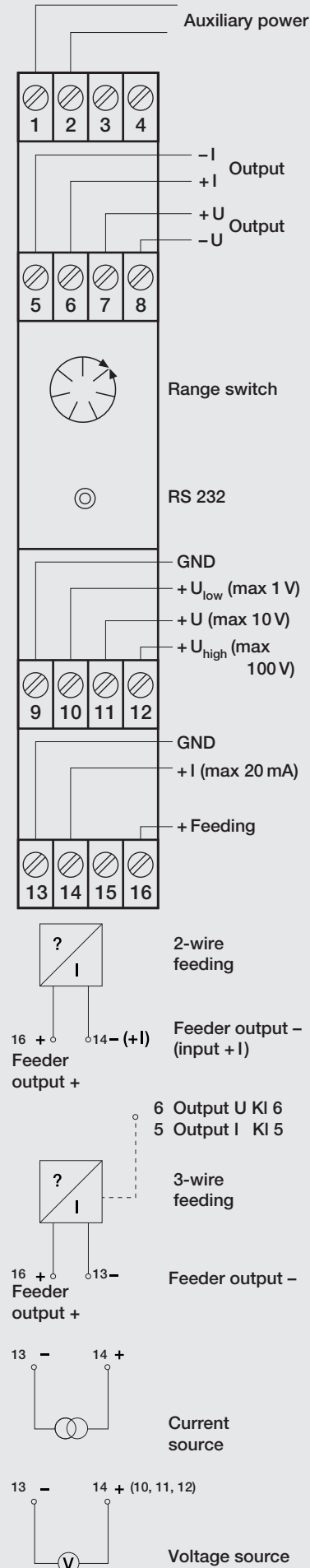

STV 2.00

**Input:**

I : impressed direct current	= 0...20mA	input resistance	≈ 10 Ω
U: impressed d.c. voltage	= 0...10(24) V	input resistance	≈ 1 MΩ
Transmitter feeding approx.:	15 V at 20 mA	I _k approx.:	30...50 mA

Output:

I : impressed direct current	= 0...20mA	permissible load	≤ 500 Ω
U: impressed d.c. voltage	= 0...10 V	permissible load	≥ 5 kΩ
	0...12 V	permissible load	≥ 6kΩ

Output limitation by switch setting F; adjustment via software

Parameterization:

Via front side turn-switch (predefined values)

Via RS232-interface* on a 3,2 mm jack socket on front side

*) SCHUHMANN Interface adapter and parameterization-software required

Adjustment of range:

Switch-setting	input I	output	Switch-setting	input I	output
0	4..20mA	4..20mA	8	20..0mA	4..20mA
0	0..20mA	0..20mA	9	0..10V	0..20mA
0	-20mA..0..20mA	-20mA..0..20mA	9	-10...10V	-20mA..0..20mA
1	4..20mA	0..20mA	A	0..10V	4..20mA
2	0..20mA	4..20mA	B	0..10V	0..10V
3	0..20mA	0..10V	B	2..10V	2..10V
3	-20mA..0..20mA	-10..10V	B	-10..10V	-10..10V
4	4..20mA	0..10V	C	60mV	0..20mA
5	20..4mA	0..20mA	C	-60mV...60mV	-20mA..0..20mA
6	20..4mA	4..20mA	D	60mV	0..10V
7	20..0mA	0..20mA	E	0..100V	4..20mA
F	user-defined adjustment				

Environmental conditions:

Storage temperature: -40...+70°C
 Operating temperature: 0...55°C
 Isolation voltage: 4kV input-output
 4kV auxiliary voltage

Auxiliary power:

Wide range: 20...253 V AC/DC
 (AC 50...60 Hz)
 First voltage range: 24 V UC (approx. 40...95 mA)

Electromagnetic compatibility law

Germany in accordance with
 EMC Directive: 2004/18/EG*
 Low-Voltage Directive: 2006/95/EG

Mounting details:

Housing with acrylic plate
 Dimensions: 22,5 x 100 x 110 mm
 Type of protection: IP 40 Gehäuse/IP 10 clamps
 Rail-mounting fixed according to
 EN 50022-35 x 7,5mm
 Connections: pluggable and encoded screw
 clamps (optional spring tension
 clamps)

For safety reasons we recommend to mount
 the top hat rail housing with a distance of
 approx. 5 mm to each other.
 Please check switch setting before initial
 operation!

02-2

Characteristics of transmission:

Sampling rate: approx. 12 kHz
 Frequency: ≤ 1 kHz sinus
 Error:
 0 Hz ≤ ± 0,1 % of final value
 at U_{output} up to max. ± 0,2 %
 1 kHz sinus ≤ 1 %

In case of user-defined adjustment the characteristic value
 refers to the selected basic range.

Temperature error: < 100 ppm/K
 Load influence I: < 50 ppm of final value
 U: < 100 ppm/K 1 kΩ

Supply voltage influence: < 0,02 % of final value
 Common mode rejection ratio > 100 dB

Isolation voltage:

Input/output 4 kV

Auxiliary voltage 4 kV

Storage temperature -20...70°C

Operating temperature 0...55°C

Ordering information:

Typ: **STV 2.00 GW** Housing for top hat rail
 wide range power

STV 2.00 GUC Housing for top hat rail
 first voltage power supply

* minimum deviations possible during HF-radiation influence