

Universal Measuring MPU 4.00 Transducer



Features:

top hat rail housing

easy adjustment

*2-, 3-, 4-conductor switch
selectable*

*high precision
ranges -50...800°C*

*simultaneous output signal
0(4)...20 mA and 0...10 V,
others on request*

*reliable isolation 4 kV
3-wire-isolation*

all functions in one device

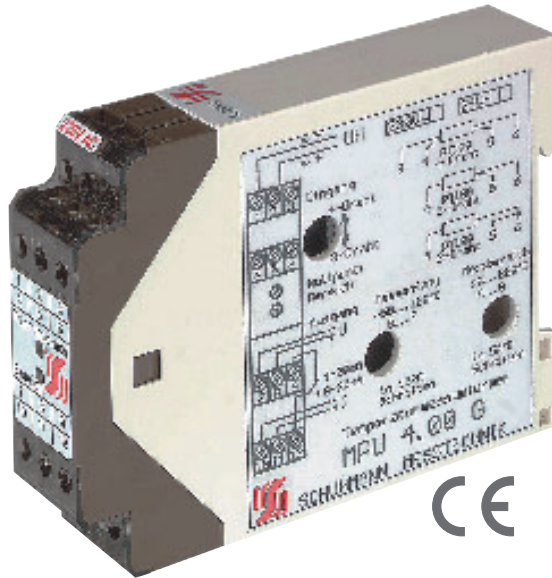

Application:

The Universal measuring transducer for Pt 100 signals is used for precise temperature measurement with resistance thermometers. Measurements can be made within a range of low and middle temperatures, e.g. in air-conditioning- and process engineering.

The flexible apply of the device is possible within the range of -50...800°C; the offset and the range can be adjusted very quickly and easily by turn switch.

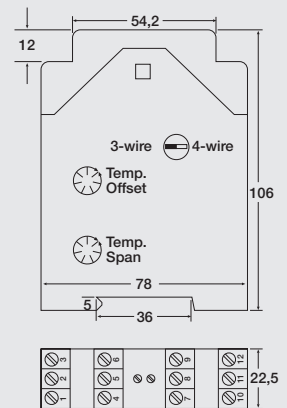

Function:

The built-in trimmers are only necessary for the fine-adjustment of the measuring signal. The resistance thermometer can be connected to the 4-conductor measuring transducer in 2-, 3-, 4-conductor-technique; both, the extra-low voltage and the mains supply version are equipped with a reliable, galvanic isolation. Input and out-

put sides have an overvoltage protection, transient protection. The device is also equipped with a simultaneous output for current 0(4)...20 mA and voltage 0...10V, other signals are available optionally. On change-over of the different temperature ranges generally no adjustment is necessary.



MPU 4.00

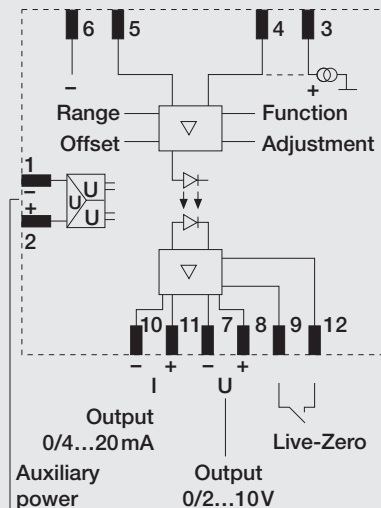
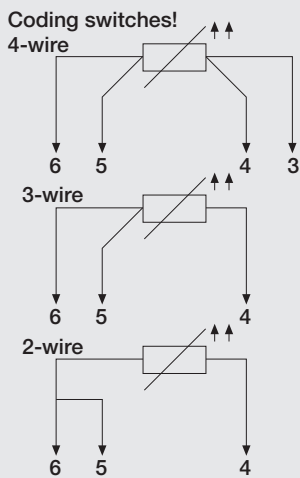
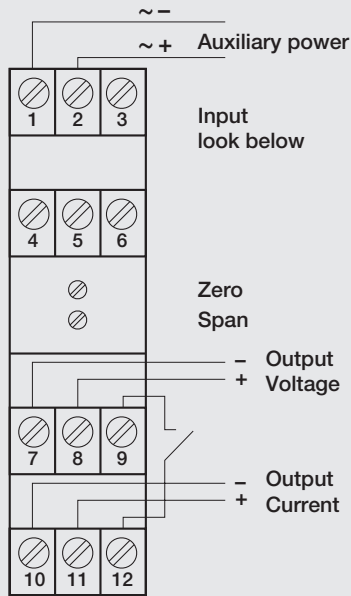

Input: The measuring ranges are adjusted by laterally integrated coding switches as follows:

Temperature-Offset		Temperature-Range	
switch	start of measuring range	switch	measuring range
0	-50 °C	0	800 °C
1	-40 °C	1	750 °C
2	-30 °C	2	700 °C
3	-20 °C	3	650 °C
4	-10 °C	4	600 °C
5	0 °C	5	550 °C
6	10 °C	6	500 °C
7	20 °C	7	450 °C
8	30 °C	8	400 °C
9	40 °C	9	350 °C
A	50 °C	A	300 °C
B	60 °C	B	250 °C
C	70 °C	C	200 °C
D	80 °C	D	150 °C
E	90 °C	E	100 °C
F	100 °C	F	50 °C

Examples:

Switch Offset = 5	Switch range = E	→	0...100 °C (standard)
Switch Offset = F	Switch range = F	→	100...150 °C
Switch Offset = 0	Switch range = C	→	-50...150 °C
Switch Offset = A	Switch range = 9	→	50...400 °C

The fine-adjustment is carried out by front-side trimmer. When changing temperature offset please check and, if necessary, readjust setting. The measuring ranges are valid for the outputs 0...10V resp. 0...20 mA. At 4...20 mA bridge on terminal 9 + 12

Span adjustment ± 15% Nullification ± 15%

Table of measuring resistance according to Pt 100 DIN IEC 751

°C	Ω	°C	Ω
-100	60,25	300	212,02
-75	70,33	325	220,88
-50	80,31	350	229,67
-25	90,19	375	238,39
0	100,00	400	247,04
25	109,73	425	255,61
50	119,40	450	264,11
75	128,98	475	272,54
100	138,50	500	280,90
125	147,94	525	289,18
150	157,31	550	297,39
175	166,61	575	305,53
200	175,84	600	313,59
225	184,99	625	321,59
250	194,07	650	329,51
275	203,08	675	337,36

Characteristics of transmission:

Linearity error:	< 0,2%
Temperature error :	< 0,7% (at 0...55°C)
Load influence:	< 0,05%
Common mode rejection ratio:	> 100 dB
Setting time:	0,5 sec. (standard)

Mounting details:

Top hat rail housing

Protection type:	IP 40 housing/IP 10 clamps
Width:	22,5 mm
Rail-housing fixed according to	EN 50022-35 x 7,5mm
Weight :	190 g

For safety reasons, we recommend to mount the top hat rail housings with a distance of approx. 5 mm to each other.

* minimum deviations possible during HF-radiation influence

Output:

Direct voltage:

0...10V	max. load 1 kΩ
concurrent working	5 kΩ
reactionless amplification	

Direct current:

0...20 mA	max. permissible load 580 Ω
4...20 mA	selectable (terminal 9/12)
output signal in case of wire break approx.	23 mA

Output Voltage / Current			
9/12	0 ... 20 mA	9/12	4 ... 20 mA
✓	0 ... 10V	✓	2 ... 10V

Electromagnetic compatibility law

Germany in accordance with
EMC Directive: 2004/18/EG*
Low-Voltage Directive: 2006/95/EG

Auxiliary power:

AC voltage:	230 V (200...250 V) AC (50...60Hz) current consumption 9 mA
-------------	---

DC voltage:	24V DC (20...30 V) current consumption approx. 60 mA
-------------	--

Influence of auxiliary power: < 0,1%

Other voltages on request

Environmental conditions:

Storage temperature:	-40...+70°C
Operating temperature:	0...55°C
Isolation voltage:	> 4 kV input-output > 4 kV auxiliary voltage AC > 3 kV auxiliary voltage DC

Ordering Information:

Type:	MPU 4.00 G Housing for top hat rail
	MPU 4.20 G Housing for top hat rail (current limiting)
	MPU 3.00 G Housing for top hat rail (constant, 2-, 3-wire)

Input details: in clear text (e.g. 20...120°C)

Output details: in clear text (e.g. 0...20 mA)

Auxiliary power: in clear text (e.g. 230V AC)