



**DIS 12.1** □

# DIS 12.1 □ Pulse Summator

## Features:

*Eurocard version or top hat rail housing*

*up to four input signals*

*no missed pulses at bouncing input contacts*

*continuous signals at input remain unconsidered*

*input pulses take place at the same time, successively or temporally overlapping*

*control alternatively contact or two-wire initiator according to EN 50227 (NAMUR)*

*auxiliary power 230 V AC or 24 V DC possible*

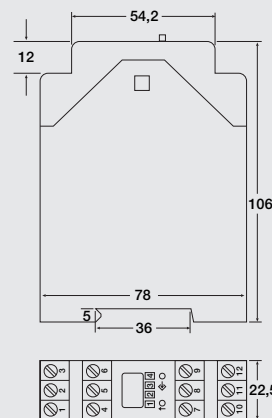
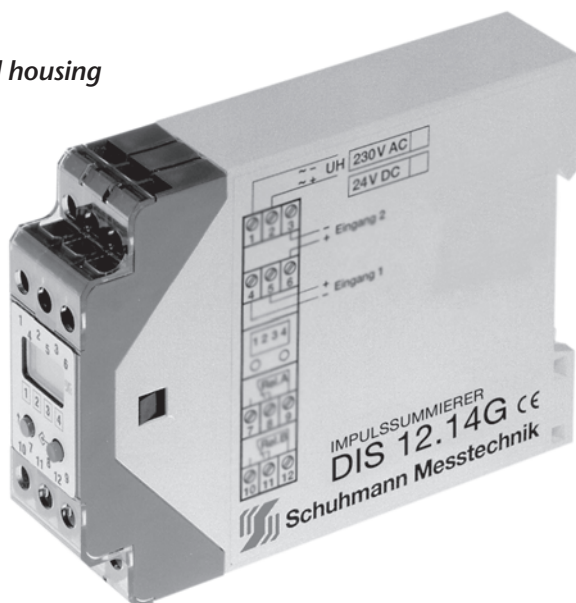

## Application:

The Pulse Summator DIS 12.14 is designed to sum up to four input signals. The control takes place by mechanical contacts, transistors, optocouplers etc. or by proximity switch of N-series (according to EN 50227 NAMUR). The sum of the four inputs in form of pulses is provided to further processing at the output of the DIS 12.14. The input pulses can take place at the same time, successively or temporally overlapping. In case of electromechanical input pulses only the maximum bounce time subject to the input frequency is to consider, therefore an input

filter to switch on is available (see technical data). The pulse duration at output is adjustable within the range of 0,05...2 seconds. The device is able to buffer up to 100 pulses, which are displayed. The output stage is formed by a relay- or transistor stage. Applications of the DIS 12.14 are e.g. in summation of up to 4 impulses in flow measurement; as component of most different counting circuits and as pulse summing up unit for manufacturing facilities respectively stations where several impulses have to be accumulated.

# DIS 12.1

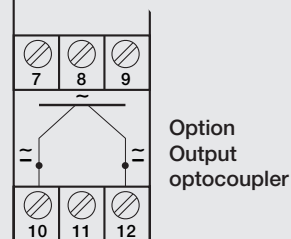
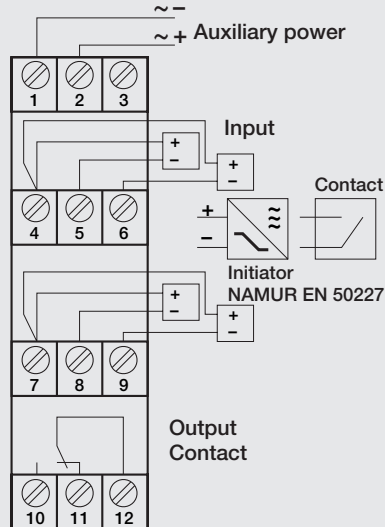

## Inputs:

Input current circuits: initiator according to NAMUR EN 50227 or potential-free contact (max. 4)

Maximum voltage:  $U_0 = 8V$ ; max. 10V

Maximum current:  $I_{max} = 4mA$

Input filter to switch on:

with filter (on): minimum input pulse 20 ms at a maximum frequency of 20 Hz

without filter (oFF): minimum input pulse 1 ms at a maximum frequency of 500 Hz

## Contact output:

### Direct current limit range

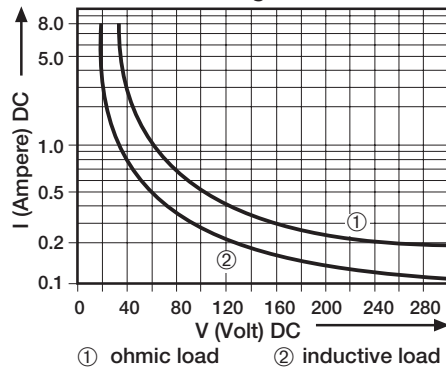

### 250V AC ohmic load

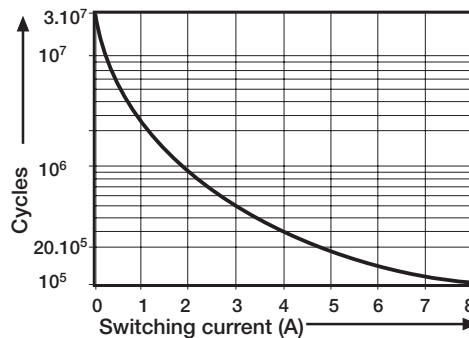

### Reduction – Contact lifetime

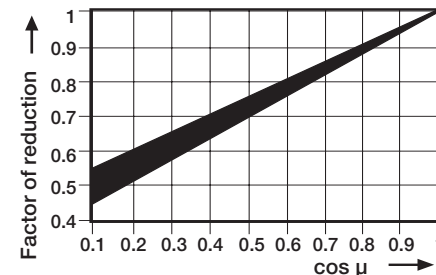

\* minimum deviations possible during HF-radiation influence

## Output current circuit:

Contact: 1 change-over contact

Mechanical lifetime:  $> 10^7$  cycles

Switching capacity: 60 VA

Contact duty: max. 250V 5 A AC

Adjustable pulse duration: 0,05...2 sec.

Option transistor output (optocoupler)

Adjustable pulse duration: 0,002...2 sec.

Switching voltage: max. 350V at 50 mA

Switching current: max. 150 mA at 5 V

## Auxiliary power:

AC voltage: 230V  $\pm$  10%

Wide range power DC:

20...45V AC (UC) / 10...70V DC

On voltage interruption the delay of turn-on time has to be considered, values from the temporary storage get lost.

Data storage non-volatile EEPROM

## Environmental conditions:

Storage temperature: -40...+70°C

Working temperature: 0...55°C

Isolation voltage:  $> 4kV$  input-output

$> 4kV$  auxiliary voltage AC

## Electromagnetic compatibility law

Germany in accordance with

EMC Directive: 2004/18/EG\*

Low-Voltage Directive: 2006/95/EG

## Mounting details:

### Housing for top hat rail

Type of protection: IP 40 housing/IP 10 clamps

Width: 22,5 mm

Rail-mounting fixed according to EN 50022-35 x 7,5mm

Weight : 210 g

For safety reasons we recommend to mount the top hat rail housing with a distance of approx. 5 mm to each other.

## Ordering information:

Type: DIS 12.14 G housing for top hat rail contact output

DIS 12.15 G housing for top hat rail transistor output

Power: 230V 230V AC

DC wide range power

Input details: in clear text (e.g. 0...10V)

Auxiliary power: in clear text (e.g. 230V AC)