

# DAF 9.00

# DAF 9.00 Digital Analog Frequency Transducer

### Features:

universally adjustable pulse transmitter  
0,001...1000 Hz

range of inputs 0(4)...20 mA,  
0...10 V

selectable range of input  
0,001...9999

potential free output contact or  
transistor output

change-over of output units:  
frequency, revolution, pulses/h

suppression of threshold value  
adjustable pulse duration

supply 230 V AC or first voltage  
range 10...70 V DC, 20...45 V AC

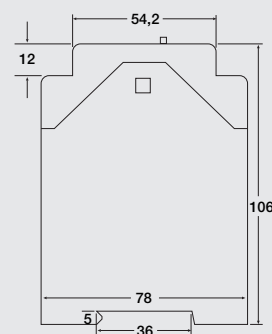
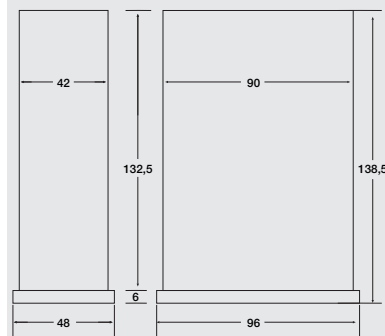
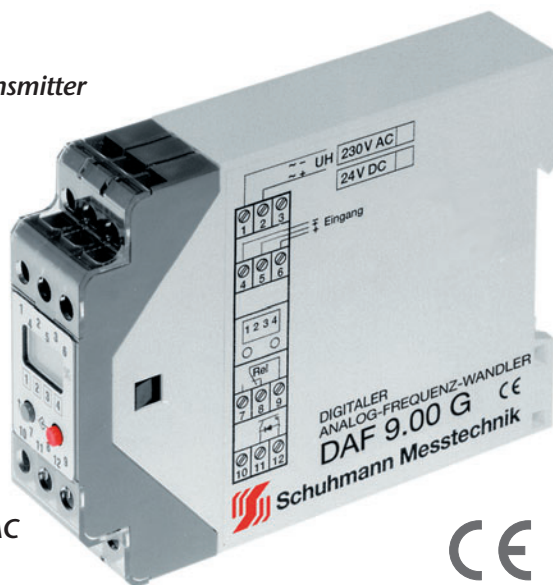

### Application:

The DAF 9.00 records consumption measurements of water, current, gas or others. The consumption is determined by the power, the power is integrated by the time.

The pulse transmitter DAF 9.00 enables the conversion of an analog signal into a pulse signal. The input value can describe a flow measurement, an electrical power or another physical

value. This input value is converted proportionally into an impulse frequency, revolution 1/min. or pulses/h. If pulses are registered by a counter or SPS-unit, the total is given.

Two function keys as well as the integrated display enable the parameterization of the Analog Frequency Transducer any time.



## MENU CONTROL

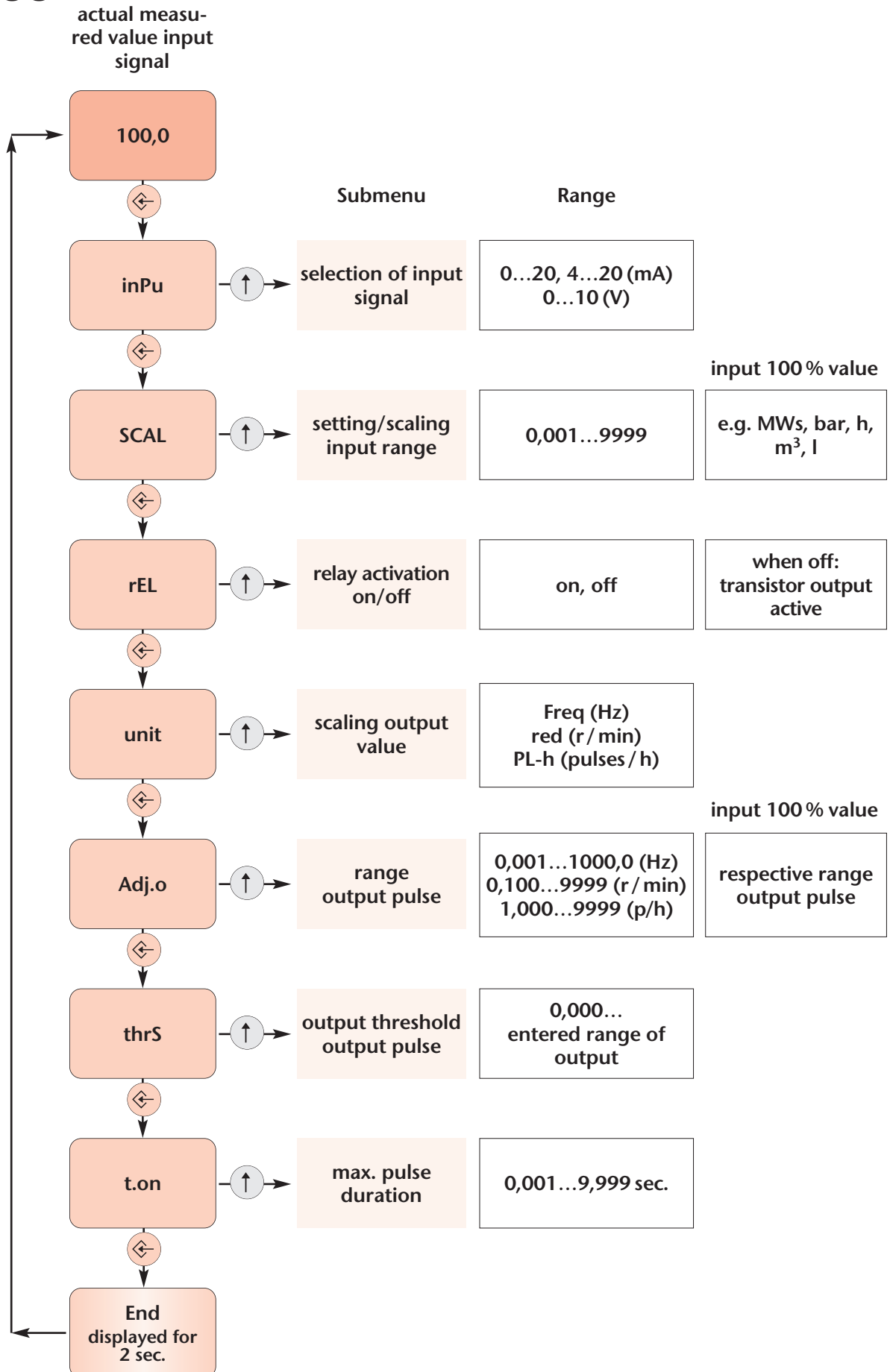

**MENU GUIDANCE: "CHANGE OF VALUES"**

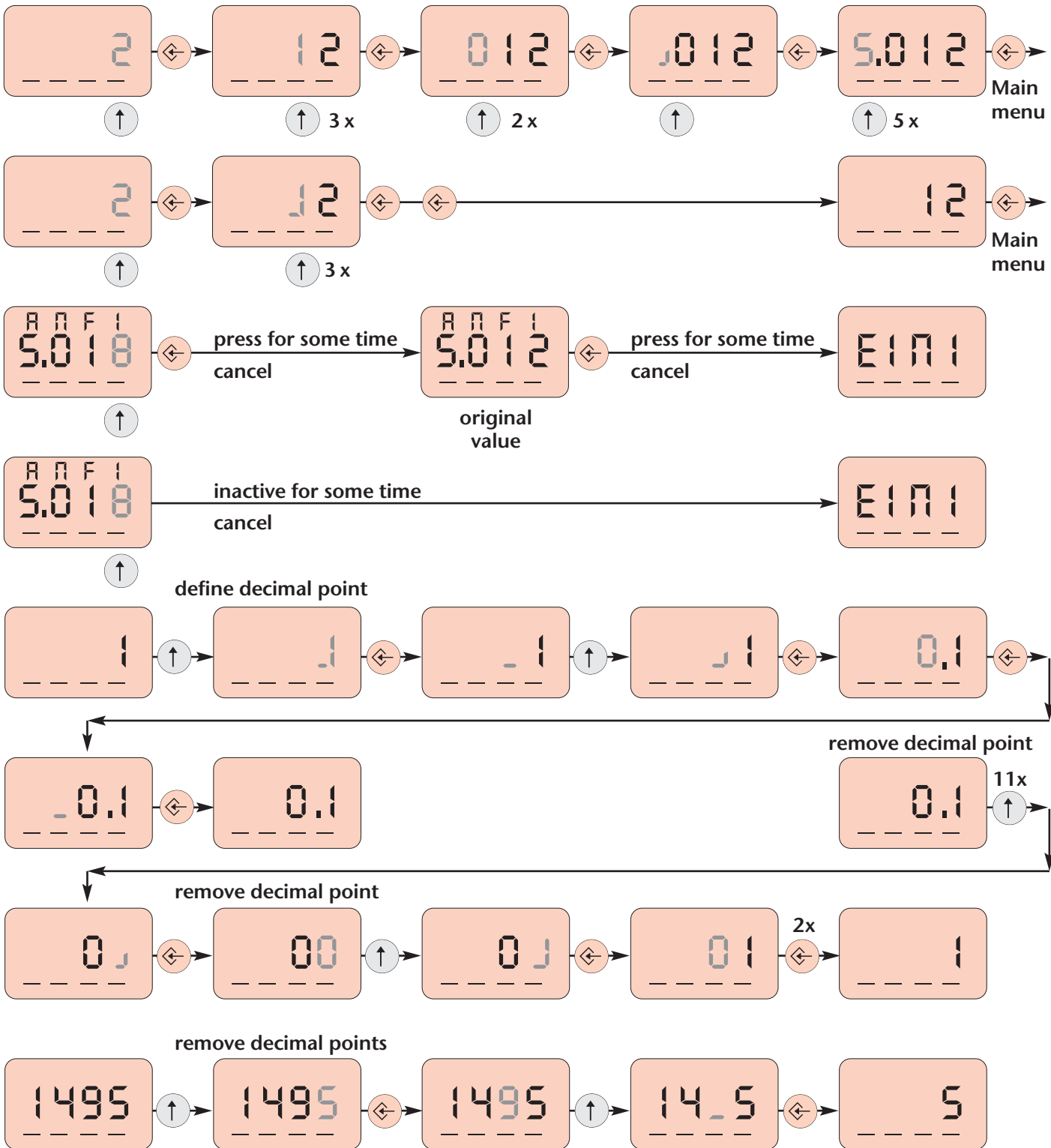

**Legend:**

- grey lined numbers : flashing on display
- J : decimal points
- : blank
- ↑ : selection
- ↔ : setting

**Notes on operation:**

Optional for housing for door installation:  
 Press red button longer than 2 sec., code inquiry. To change parameters you have to enter the predetermined code number here, otherwise only view is possible.

# DAF 9.00

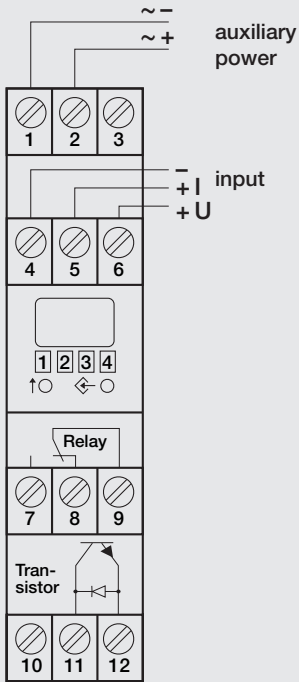

### Inputs:

selected via menu:  
 I: 0(4)...20 mA      input resistance 50 Ω  
 U: 0...10V          input resistance 100kΩ

### Input display:

free scaling:          0,001...9999

### Outputs:

1 transistor and 1 relay output  
 (relay up to 1 Hz selectable, please pay attention to the contact lifetime)

### Transistor:

max. 50 V DC, max. 50 mA  
 Final value:          0,001...1000 Hz  
                               36...9999 pulses/h  
 Pulse duration:      0,001...9,999 sec.

### Relay:

max. 8 A at 230 V AC / 24 V DC (ohmic load)  
 max. switching voltage:      250 V AC  
 Contact lifetime:            30 x 10<sup>6</sup> cycles  
 Final value:                0,001...1,000 Hz  
                                      36...3600 pulses/h  
 Pulse duration:            0,100...9,999 sec.

### Pulse duration / frequency:

If the output frequency is higher as it would be by the transistor-/relay pulse duration instructions, the pulse duration is set at a feasible value. You have to consider that the pulse duration at the display doesn't change.

### Threshold/suppression of residual quantities:

The output signals can be blocked by the function of suppression of residual quantities. The threshold is entered related to the output signal.

### Exactitude, influence of linearity:

0,1 % if final value      = 1000 Hz  
 0,03 % if final value    ≤ 100 Hz  
 influence of temperature: < 30 ppm/°C

### Auxiliary power:

Wide range power:    20...253 V AC / DC  
                               (50...60 Hz) power  
                               consumption 4 VA  
 First voltage range:    24 V UC (20...30V) power  
                               consumption approx. 2VA

Top hat rail construction:  
 a.c. voltage:            230V ± 10 %

Wide range power DC:  
                               20...45 V AC (UC) / 10...70 V DC

On voltage interruption the delay of turn-on time has to be taken into account. Values from the temporary storage get lost.

Data storage:          non-volatile EEPROM

### Environmental conditions:

Storage temperature:    -40...+70°C  
 Operating temperature: 0...55°C  
 Isolation voltage:      > 4kV inputs-outputs  
                               > 4kV auxiliary voltage

### Electromagnetic compatibility law

Germany in accordance with  
 EMC Directive: 2004/18/EG\*  
 Low-Voltage Directive: 2006/95/EG

### Mounting details:

**Housing for top hat rail**  
 Type of protection: IP 40 housing/IP 10 clamps

Width:                    22,5 mm  
 Rail mounting fixed according to  
                               EN 50022-35 x 7,5mm

Weight :                250 gm

**For safety reasons we recommend to mount the top hat rail housing with a distance of approx. 5 mm to each other.**

### Housing for door installation

Type of protection: IP 54 front  
 Front panel:          96 x 48 mm  
 Mounting depth:    138,5 mm  
 Housing material:    PC / ABS self-extinguishing  
                               according to UL94V-0

Electrical connections via removable screw terminal strip

Weight:                290 gm

### Ordering information:

Type: **DAF 9.00 G** housing for top hat rail  
           **DAF 9.00 T** housing for door installation  
 Power supply: **W** wide range power  
                   **UC** first voltage range  
                   **230 V** 230 V AC  
                   **DC** wide range power  
                          first voltage range  
 Input information: in clear text (e.g. 0...10V)  
 Auxiliary power:    in clear text (e.g. 230 V AC)

### DAF 9.00 T

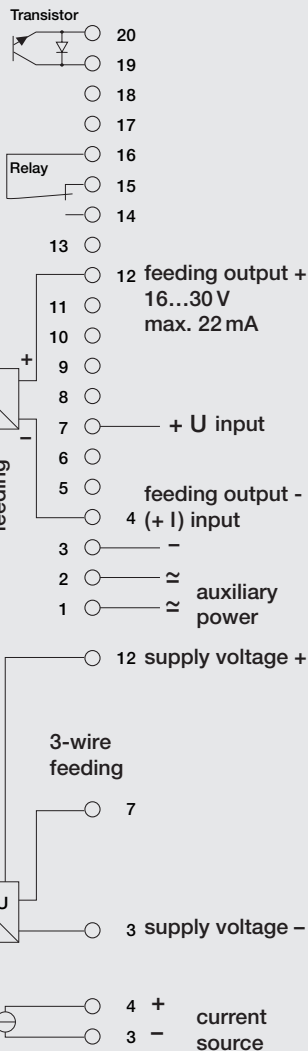

### D.C. limit range

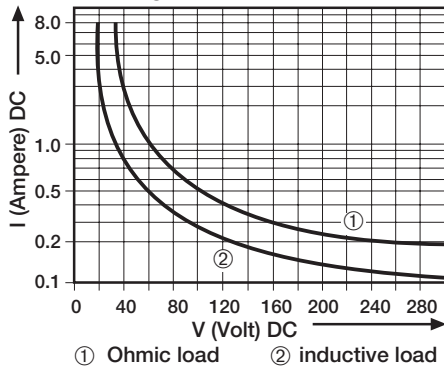

### Reduction – contact lifetime

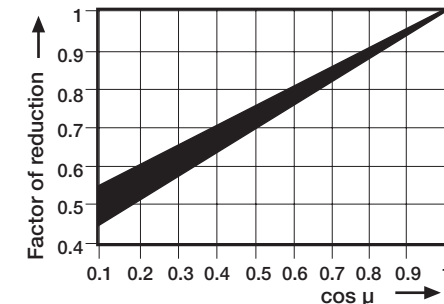

### 250V AC Ohmic load

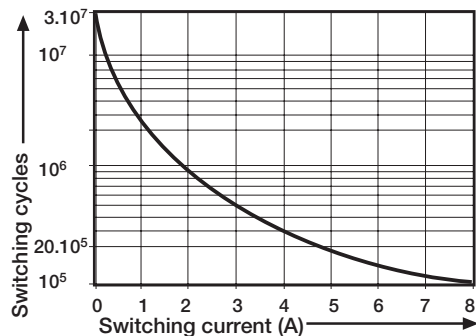

\* minimum deviations possible during HF-radiation influence